



---

<b>INTRODUCTION</b>		2
---------------------	--	---

---

<b>REASON 1</b>	Low Temperature Coefficient of Resistance (TCR) and Low Power Coefficient (WCR)	2
-----------------	---	---

---

- Absolute
- Tracking
- WCR (Power Coefficient)
- Power Current Sensing Resistors

---

<b>REASON 2</b>	Resistance Tolerance	4
-----------------	----------------------	---

---

- Absolute
- Ratio

---

<b>REASON 3</b>	Load-Life Stability	5
-----------------	---------------------	---

---

<b>REASON 4</b>	Current Noise	6
-----------------	---------------	---

---

<b>REASON 5</b>	High Speed and Response Time	7
-----------------	------------------------------	---

---

<b>REASON 6</b>	Low Thermal EMF	8
-----------------	-----------------	---

---

<b>REASON 7</b>	Non-Measurable Voltage Coefficient	9
-----------------	------------------------------------	---

---

<b>CONCLUSION</b>		9
-------------------	--	---

---

For technical information please contact,  
for the Americas: [Foilsupport1@Vishay.com](mailto:Foilsupport1@Vishay.com),  
for Asia / Japan / Europe / Africa / Israel: [Foilsupport2@Vishay.com](mailto:Foilsupport2@Vishay.com)

For marketing information please contact,  
for the Americas: [Foilsales.usa@Vishay.com](mailto:Foilsales.usa@Vishay.com),  
for Asia / Japan: [Foilsales.asia@Vishay.com](mailto:Foilsales.asia@Vishay.com),  
for UK / Holland / Scandinavia: [Foilsales.eunorth@Vishay.com](mailto:Foilsales.eunorth@Vishay.com),  
for Germany / Czech Republic / Austria: [Foilsales.eucentral@Vishay.com](mailto:Foilsales.eucentral@Vishay.com),  
for France / Switzerland / Southern Europe: [Foilsales.eusouth@Vishay.com](mailto:Foilsales.eusouth@Vishay.com),  
for Israel: [Foilsales.israel@Vishay.com](mailto:Foilsales.israel@Vishay.com).

## Seven Technical Reasons to Specify Bulk Metal® Foil

### INTRODUCTION

More than four decades after its invention by physicist Dr. Felix Zandman in 1962, Bulk Metal® Foil (BMF) technology still outperforms all other resistor technologies available today for applications that require precision, stability, and reliability. Vishay offers Bulk Metal Foil products in a variety of resistor configurations and package types to meet the needs of a wide range of applications.

In 2000, Vishay achieved a technological breakthrough with the introduction of Bulk Metal Z-Foil®. Products built on this revolutionary technology deliver an absolute temperature coefficient of resistance (TCR) of 0.2 ppm/°C. The lower the TCR, the better a resistor can maintain its precise value despite ambient temperature variations and self-heating when power is applied.

By taking advantage of the overall stability and reliability of Vishay Bulk Metal® Foil resistors, designers can significantly reduce circuit errors and greatly improve overall circuit performance.

Bulk Metal technology allows Vishay to produce customer-oriented products designed to satisfy challenging and specific technical requirements. Customers are invited to contact our Application Engineering Department with non-standard technical requirements and special applications (email: foilsupport1@vishay.com).

### KEY FEATURES

- Nearly zero absolute TCR:  $\pm 0.2$  ppm/°C (MIL range) with Bulk Metal Z-Foil® technology
- TCR tracking: to 0.1 ppm/°C
- Change of resistance value due to applied power: WCR=5 ppm at rated power
- Load life stability under applied power:
  - As low as 0.005% at +70 °C, 2000 hours for SMD chips
  - As low as 0.005% at +125 °C, 2000 hours for leaded resistors
- Broad resistance range: 2 m $\Omega$  to 3.3 M $\Omega$ .
- Tolerance: Absolute and match for voltage divider and networks to  $\pm 0.001\%$
- Four-terminal connections
- Low current noise: < -40 dB
- Voltage coefficient: < 0.1 ppm/V
- Non-inductive: < 0.08  $\mu$ H
- High speed and response time: 1 ns
- Low thermal EMF: 0.05  $\mu$ V/°C
- Lead (Pb)-free and RoHS-compliant parts available on request

### RANGE OF FOIL RESISTOR PRODUCTS

- Surface mount chips, molded resistors and networks
- Power current sensors
- Military established reliability
- Leaded (Through-Hole)
- Hermetically-sealed and molded discrete resistors and networks
- Trimmers
- Voltage dividers
- Hybrid chips

### REASON 1

#### LOW TEMPERATURE COEFFICIENT OF RESISTANCE (TCR)

“Why are extremely low TCR resistors required?” is a proper question when evaluating the performance and cost of a system. The answers are as numerous as the systems in which they are installed. The following may provide an insight:

A remote TV transmitter that starts up cold in the morning and warms up during the day requires manual color discrimination adjustment during the day due to the influence of the temperature changes.

Satellites in synchronous orbit that require stable position and function, or one that rotates through temperature extremes.

The solution to these problems is extremely low absolute TCR resistors.

#### FOIL TCR

Two predictable and opposing physical phenomena within the composite structure of the resistive alloy and its substrate are the key to the low TCR capability of Bulk Metal® Foil:

- Resistivity of the resistive alloy changes directly with temperature. (Resistance of the foil increases when temperature increases.)
- The coefficient of thermal expansion of the alloy and substrate are different resulting in a compressive stress on the resistive alloy when temperature increases. (Resistance of the foil decreases due to compression caused by the temperature increases.)

The temperature coefficient of Vishay Bulk Metal® Foil resistors is the result of matching the variation in resistivity of the alloy with temperature and variation of the resistance of the alloy with stress. These two effects occur simultaneously with changes in temperature. The result is an unusually low and predictable TCR.

Due to Vishay's Bulk Metal® Foil resistor design, this TCR characteristic is accomplished automatically, without selection, and regardless of the resistance value or the date of manufacture — even if years apart!

#### IMPROVED TCR IN BULK METAL® FOIL RESISTORS TO $\pm 0.2$ PPM/°C

Foil resistor technology has continued to progress over the years, with significant improvements in TCR. Figure 1 shows the typical TCR characteristics of the various foil alloys utilized by Vishay to produce Bulk Metal® Foil resistors.

The original Alloy C Foil exhibits a negative parabolic response to temperature with a positive chord slope on the cold side and a negative chord slope on the hot side.

Following was the Alloy K Foil which produced an opposite parabolic response with temperature with a negative chord

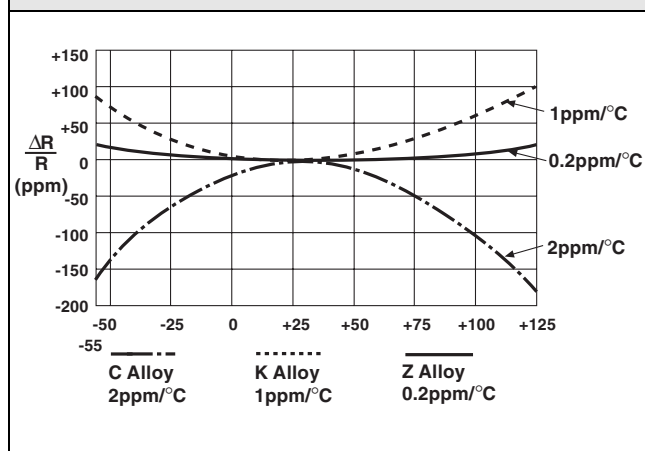
slope on the cold side and a positive chord slope on the hot side. In addition, it provides a TCR approximately one half that of Alloy C Foil.

The latest development is the Alloy Z Foil Technology Breakthrough which has a similar parabolic response as the Alloy K Foil but produces TCR characteristics an order of magnitude better than Alloy C and five times better than Alloy K.

Extremely low TCR resistors have been developed that provide virtually zero response to temperature. See the data sheet for the Vishay Thermotropic VHP100, ultra performance Z201, hermetically sealed VH102Z resistors and Foil Surface-Mount Chip resistors: VSMP series, VFCE series and VCS2516Z.

These technological developments have resulted in a major improvement in TCR characteristics compared to what was available from Vishay before, and what is available in any other resistor technology. Use Bulk Metal® Foil resistors for all extremely low TCR requirements.

**FIGURE 1. FOIL RESISTOR TCR  
COMPARISON OF FOIL ALLOYS  
IN MILITARY RANGE**



### TYPICAL TCR

Vishay Typical TCR is defined as the chord slopes of the relative change of resistance vs temperature (RT) curve, and is expressed in ppm/°C (parts per million per degree centigrade). Slopes are defined from 0 °C to + 25 °C and + 25 °C to + 60 °C (Instrument Range); and from - 55 °C to + 25 °C and + 25 °C to + 125 °C (Military Range). These specified temperatures and the defined typical TCR chord slopes apply to all resistance values including low value resistors. Note, however, that without four terminals and Kelvin connections in low values, allowance for lead resistance and associated TCR may have to be made. All resistance and TCR measurements of leaded styles are made by the factory at a gage point 1/2" from the standoffs. Contact Applications Engineering Department for the TCR increase to be expected for low value resistors.

### UNDERSTANDING RESISTOR FIGURES OF MERIT

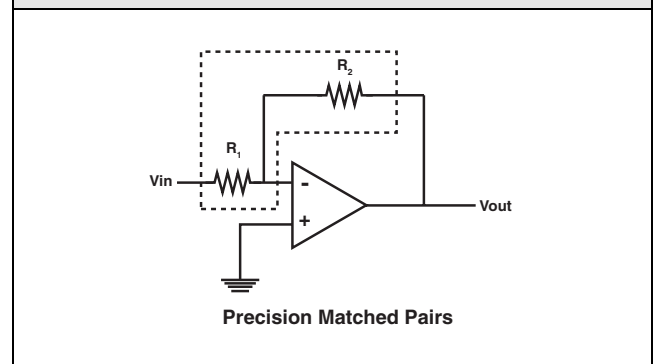
#### TCR TRACKING

When more than one resistor shares the same substrate, the TCR tracking will be much better than the TCR provided by two discrete resistors. Resistors with different technologies increase or decrease in value when temperatures change. Resistance ratio tracking is influenced by heat that comes from outside the device (such as a rising ambient temperature or adjacent hotter objects) and from inside the device (as a result of self-heating due to power dissipation). Absolute TCR and Tracking are particularly important figures of merit in the case of two resistances, even with similar TCR characteristics. The amplification ratio will be affected by using a pair of resistors having the same high TCR (and therefore good tracking). The ratio will change when there is a temperature difference between the two resistors. This is why it is important to have also low absolute TCR, not only good tracking.

The best analog design would be using a fundamentally low absolute TCR resistor since it would minimize the effect of ambient temperature and self-heating.

This is impossible to accomplish with high TCR resistors even with good initial TCR Tracking.

### TYPICAL APPLICATION



### POWER COEFFICIENT (WCR)

The TCR of a resistor for a given temperature range is established by measuring the resistance at two different ambient temperatures: at room temperature and in a cooling chamber or oven. The ratio of relative resistance change and temperature difference gives the slope of  $\Delta R/R = f(T)$  curve. This slope is usually expressed in parts per million per degree Centigrade (ppm/°C).

In these conditions, a uniform temperature is achieved in the measured resistance. In practice, however, the temperature rise of the resistor is also partially due to self-heating as a result of the power it is dissipating. Therefore, the TCR alone does not provide the actual resistance change. Hence, another figure of merit, WCR (power coefficient), was introduced. WCR is expressed in parts per million per Watt or in ppm at rated power. In the case of Z-based Bulk Metal® Foil, the WCR is 5 ppm typical at rated power or 4 ppm per watt for power resistors.

## POWER CURRENT SENSING RESISTORS

High precision resistors used for current sensing are usually low ohmic value devices suitable for four terminal connections. Two terminals are connected to allow the electrical current pass through the resistor. Voltage drop (V) is measured on the other two terminals, called “Sense” or “Voltage drop” terminals.

This “Kelvin connections” arrangement reduces, especially for low ohmic resistance values, a measurement error due to the resistance of the lead wires and solder joints as the sensing is performed inside the resistor, in or close to the active resistive foil.

The high precision power current sense foil resistors are best suited for manufacture at low values due to superior stability compared to thick film or thin film resistors.

Vishay achieves very high precision in current sensing by:

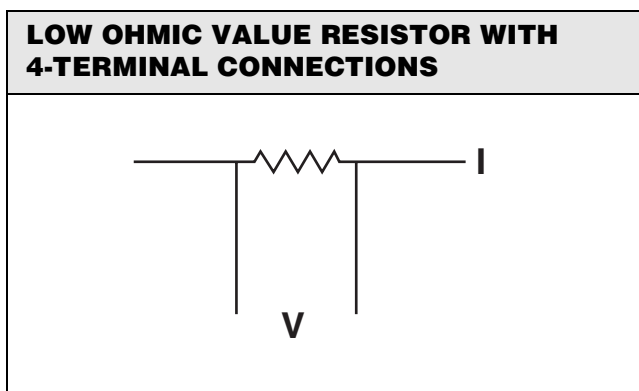
- Using Z-foil for very low TCR (0.2 ppm/ °C typical) over wide temperature ranges
- Z-Foil also provides a very low WCR (power coefficient of resistance) of 4 ppm/Watt typical for power resistors
- Applying proprietary methods of manufacturing precision four terminal resistors
- Applying its expertise in stress analysis

Examples of Vishay high precision power current sensing Z-Foil resistors:

Leaded: VHP4Z, VPR247Z, VFP4Z, VCS331Z, VCS332Z, VCS232Z, VPR220Z, VPR221Z

SMD: VCS2516Z

For more details about resistor styles, please visit [www.vishay.com/resistors-discrete/metal-foil/](http://www.vishay.com/resistors-discrete/metal-foil/)



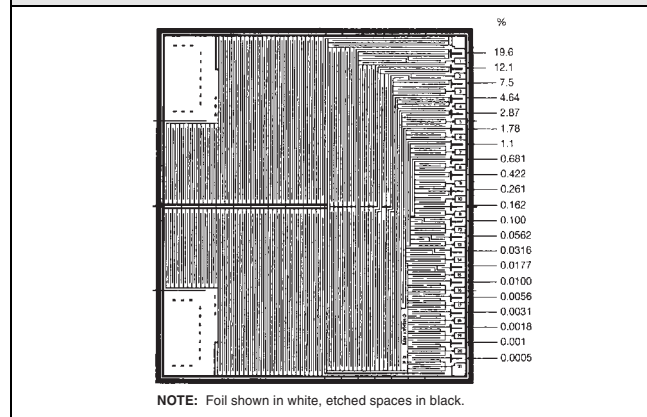
## REASON 2

### TIGHT RESISTANCE TOLERANCE

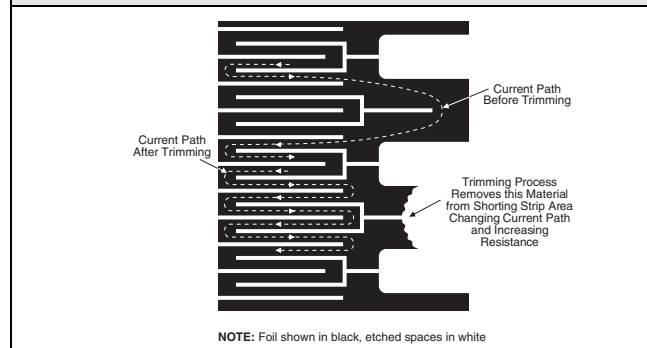
Why do users employ tight tolerance resistors? A system or a device or one particular circuit element must perform for a specified period of time and at the end of that service period it must still be performing within specification. During its useful life it may have been subjected to some hostile service conditions and it is no longer within purchased tolerance. One reason for specifying a tighter purchased tolerance than the end of life error budget tolerance is to allow room for service shifts. Another reason is that the error budget is more economically applied to resistors than to most other components.

The accuracy of Bulk Metal® Foil resistors can be made as precise as **0.001%** by selectively trimming various adjusting points that have been designed into the photoetched pattern of the resistive element (See Figure 2). They provide predictable step increases in resistance to the desired tolerance level. Trimming the pattern at one of these adjusting points will force the current to seek another longer path, thus raising the resistance value of the element by a specific percentage. In the fine adjust areas, trimming affects the final resistance value by smaller and smaller amounts down to 0.001% and finally 0.0005% (5 ppm). This is the trimming resolution (See Figure 3).

**FIGURE 2. VISHAY S102C RESISTOR ELEMENT**



**FIGURE 3. TRIMMING TO VALUES (CONCEPTUAL ILLUSTRATION)**

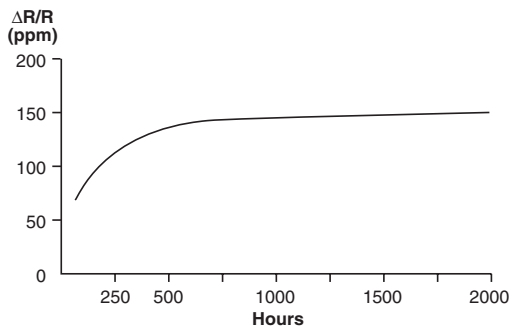


### REASON 3 EXCELLENT LOAD-LIFE STABILITY

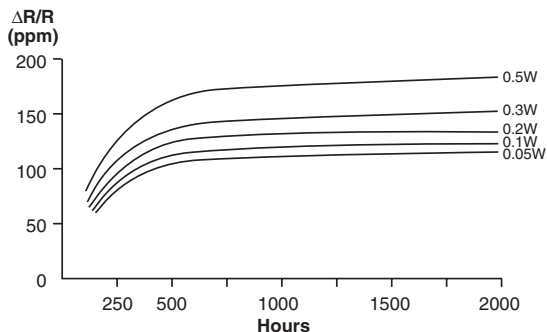
Why are designers concerned about stability with applied load? Load-life stability is the characteristic most relied upon to demonstrate a resistor's long-term reliability. Military testing requirements to 10,000 hours with limits on the amount of shift and the number of failures result in a failure rate demonstration. Precision Bulk Metal® Foil resistors have the tightest allowable limits. Whether military or not, the load-life stability of foil resistors is unparalleled and long-term serviceability is assured.

The reason foil resistors are so stable has to do with the materials of construction (Bulk Metal® Foil and high alumina substrate). For example, the S102C resistor is rated at 0.3 W at 125 °C with an allowable  $\Delta R$  of 150 ppm after 2000 hours under load. (See Figures 4 and 5 for the demonstrated behavior). Conversely, the  $\Delta R$  is reduced by decreasing the applied power which lowers the element temperature rise in Vishay resistors. Figure 4 shows the drift due to load-life testing at rated power and Figure 5 shows the drift due to load-life testing at reduced power. Reducing the ambient temperature has a marked effect on load-life results and Figure 6 shows the drift due to rated power at different ambient temperatures. The combination of lower power and ambient temperature is shown in Figure 7.

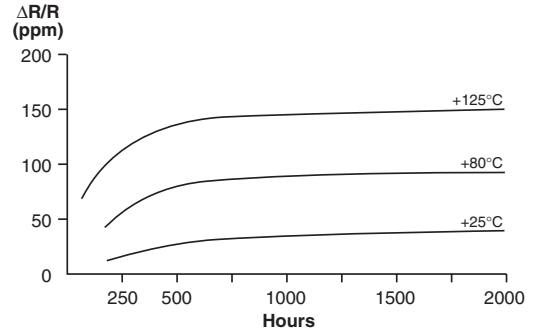
**FIGURE 4. RELATIVE RESISTANCE CHANGE ( $\Delta R/R$ ) AS A FUNCTION OF TIME, LOAD 0.3W, +125 °C AMBIENT**



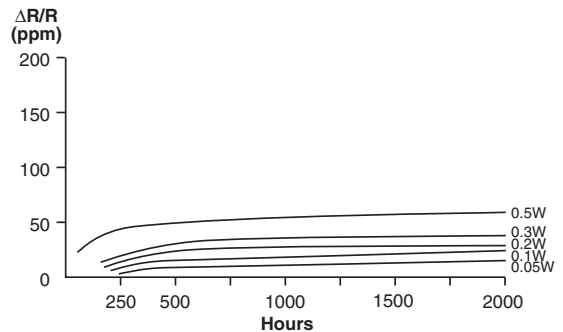
**FIGURE 5.  $\Delta R/R = F$  (TIME), LOADS 0.05 TO 0.5 W, +125 °C AMBIENT**



**FIGURE 6.  $\Delta R/R = F$  (TIME), LOADS 0.3 W, DIFFERENT AMBIENT TEMPERATURES**



**FIGURE 7.  $\Delta R/R = F$  (TIME), LOADS 0.05 TO 0.5 W, +25 °C AMBIENT**



For evaluation of load-life stability, the two parameters which must be mentioned together, power rating and ambient temperature, can be joined into one single parameter for a given style of resistor. If the steady state temperature rise can be established, it can be added to the ambient temperature, and the sum will represent the combined (load induced + ambient) temperature. For instance, the Vishay S102C resistor has a temperature rise of 9 °C per 0.1 W of applied power. It leads to the following sample calculations:

If  $T = 75$  °C,  $P = 0.2$  Watts, and  $t = 2,000$  hrs. ;  
Then self-heating =  $9$  °C  $\times 2 = 18$  °C.

$18$  °C rise +  $75$  °C ambient =  $93$  °C total.

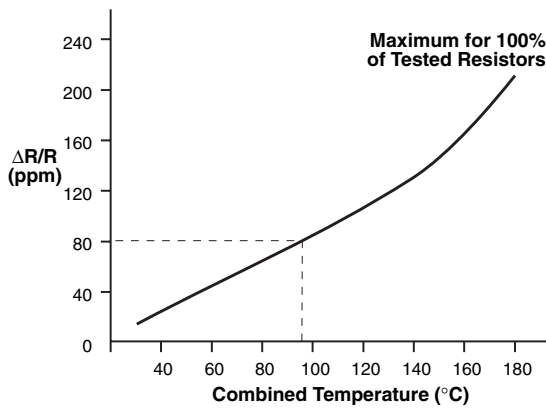
$\frac{\Delta R}{R}$

$R$  max = 80 ppm from the curve of Figure 8.

Figure 8 shows, for a given duration of load life test, how the drift increases with the level of the applied combined temperature. As explained above, the combined temperature comprises the effect of power induced temperature rise and the ambient temperature. The curve shows maximum drift.

**FIGURE 8. MAXIMUM RESISTANCE SHIFTS AFTER 2 000 HRS. OF LOAD LIFE TEST UNDER THERMAL STRESSES\***

\*Combined temperature— ambient and temperature rise due to applied power.



This information is based on product taken off the line without any screen testing or burn in. Further drift reduction is available by factory burn in. Consult Applications Engineering for this and other screening tests that are available.

## REASON 4 HIGH SPEED AND RESPONSE TIME

The equivalent circuit of a resistor, as shown in Figure 9, combines a resistor in series with an inductance and in parallel with a capacitance. Resistors can perform like an R/C circuit or filter or inductor depending on their geometry. In spiraled and wirewound resistors, these reactances are created by the loops and spaces formed by the spirals or turns of wire. Figure 10 shows how the capacitance and inductance increase as the resistance value increases due to continually increasing the number of spirals or turns.

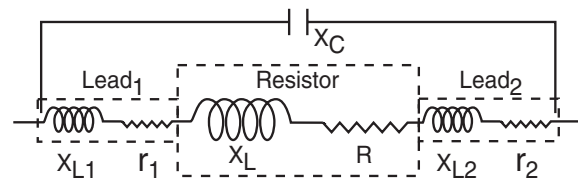
In planar resistors such as the Vishay Bulk Metal® Foil resistors, the geometry of the lines of the resistor patterns are intentionally designed to counteract these reactances. Figure 11 shows a typical serpentine pattern of a planar resistor. The opposing directions of current prevents the build-up of mutual inductance and reduces the capacitive effects by placing the inter-conductor capacitances in series.

In pulse applications, these reactive distortions result in a poor replication of the input. Figure 12 shows the current response to a voltage pulse comparing a fast Bulk Metal® Foil resistor to a slower wirewound. Here a pulse width of one nanosecond would have been completely missed by the wirewound resistor while the foil resistor achieves full replication in the time allotted.

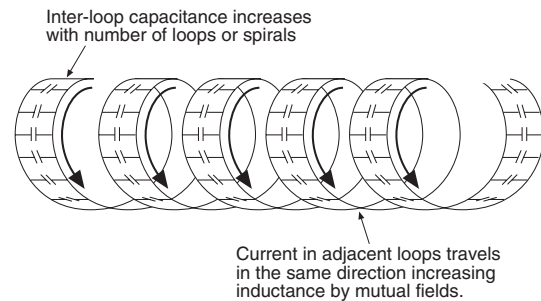
In frequency applications, these reactive distortions also cause changes in apparent resistance (impedance) with changes in frequency. Figure 13 shows a family of curves

relating the AC resistance to the DC resistance in Bulk Metal® Foil resistors. Very good response is seen in the 100 ohm range out to 100 MHz and all values have good response out to 1 MHz. The performance curves for other types of resistors can be expected to show considerably more distortion (particularly wirewounds).

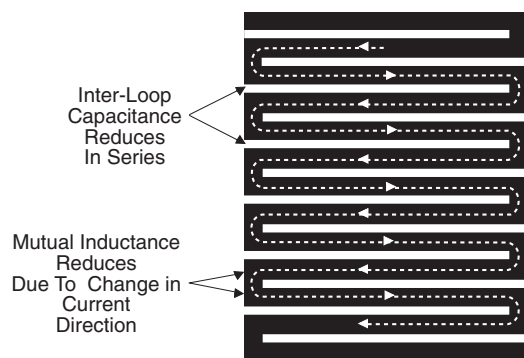
**FIGURE 9. THE EQUIVALENT CIRCUIT OF A RESISTOR**



**FIGURE 10. CAPACITANCE AND INDUCTANCE IN A WOUND OR SPIRALED RESISTOR**

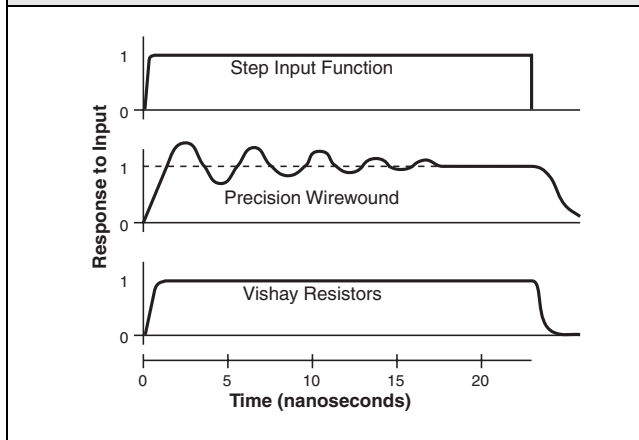


**FIGURE 11. BULK METAL® FOIL PLANAR DESIGN**

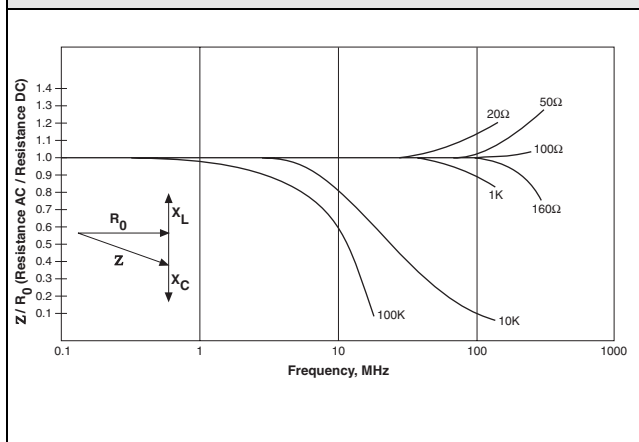




**FIGURE 12. COMPARISON OF A RESPONSE TO A PULSE**



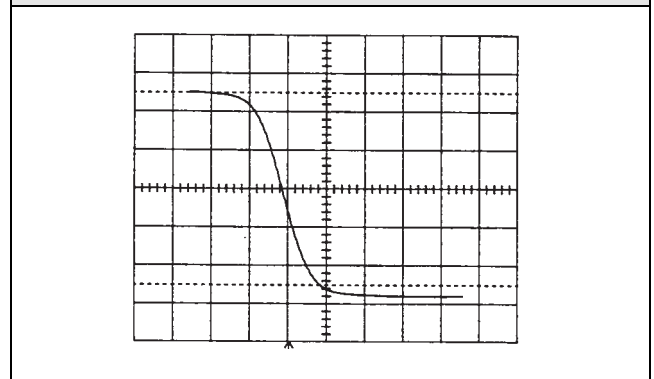
**FIGURE 13. EFFECT OF OPERATION AT FREQUENCY**



### REASON 5 LOW NOISE; “HEAR THE DIFFERENCE”

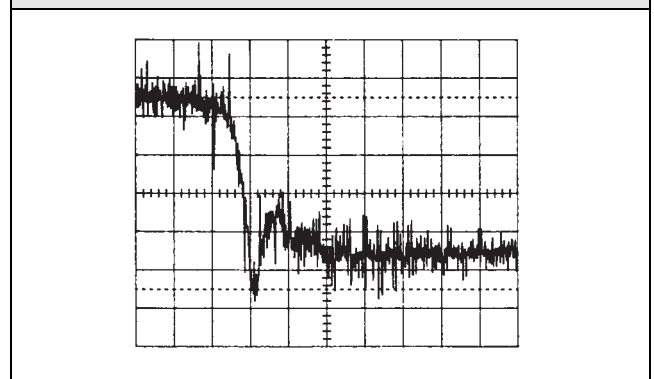
As sound reproduction requirements become more demanding, the selection of circuit components become more exacting and the resistors in the signal path are critical. Measurement instrumentation based on low level signal inputs and high gain amplification cannot tolerate microvolt level background noise when the signal being measured is itself in the microvolt range. Although audio circuitry, when signal purity is of utmost concern, is the most obvious use of noise-free components, other industries and technologies are equally concerned with this characteristic.

**FIGURE 14. SEGMENT OF A FUNDAMENTAL CURVE**

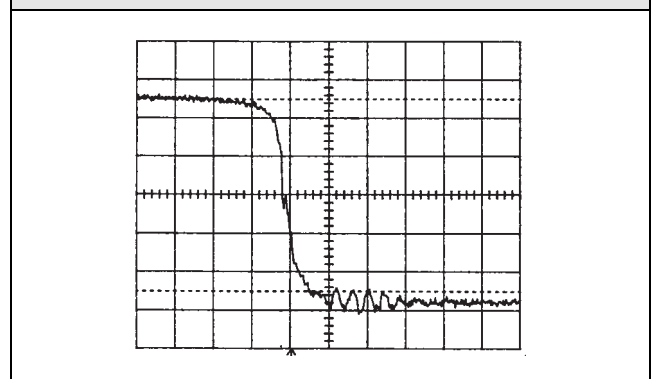


Resistors, depending on construction, can be a source of noise. This unintended signal addition is measurable and independent of the presence of a fundamental signal. Figures 15 and 16 illustrate the effects of resistor noise on a fundamental signal.

**FIGURE 15. SIGNAL WITH ADDED RESISTOR NOISE**

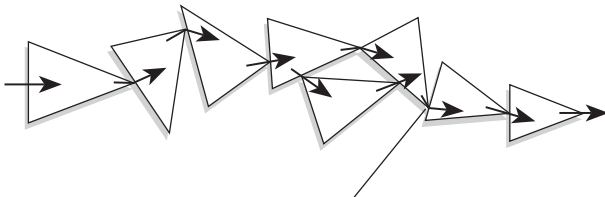


**FIGURE 16. SIGNAL WITH A “NOISE-FREE” RESISTOR**



Resistors made of conductive particles in a non-conductive binder are the most likely to generate noise. In carbon composition and thick film resistors, conduction takes place at points of contact between the conductive particles within the binder matrix. Where these point-to-point contacts are made constitutes a high resistance conduction site which is the source for noise. These sites are sensitive to any distortion resulting from expansion mismatch, moisture swelling, mechanical strain, and voltage input levels. The response to these outside influences is an unwanted signal as the current finds its way through the matrix. Figure 17 illustrates this current path.

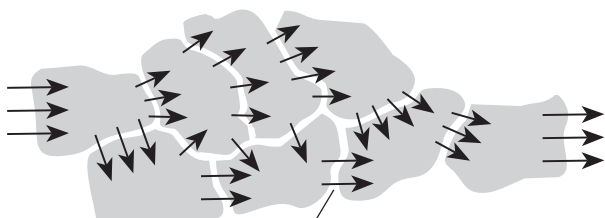
**FIGURE 17. THE CURRENT PATH IN A PARTICLE-TO-PARTICLE MATRIX**



Noise generation is maximum when current flow is through point to point contacts as shown in a particle to particle matrix.

Resistors made of metal alloys, such as the Vishay Bulk Metal<sup>®</sup> Foil resistor, are the least likely to be noise sources. Here the conduction is across the inter-granular boundaries of the alloy. The intergranular current path from one or more metal crystals to another involves multiple and long current paths through the boundaries reducing the chance for noise generation. Figure 18 illustrates this current path.

**FIGURE 18. THE CURRENT PATH IN A RESISTIVE ALLOY**



Noise generation is minimal when current flow is through multiple paths as exists in Bulk Metal<sup>®</sup> Foil resistive alloy.

In addition, the photo lithography and fabrication techniques employed in the manufacture of Bulk Metal<sup>®</sup> Foil resistors results in more uniform current paths than found in some

other resistor constructions. Spiraled resistors, for example, have more geometric variations that contribute to insertion of noise signals. Bulk Metal<sup>®</sup> Foil resistors have the lowest noise of any resistor technology, with the noise level being essentially immeasurable. Signal purity can be a function of the selection of resistor technology for pre-amp and amplifier applications. Vishay Foil Resistors offer the best performance for low noise audio applications.

## REASON 6 LOW THERMAL EMF

The thermoelectric effect, which is negligible in ordinary resistors, may become a significant noise source of drift or instability in high-precision resistors. Known as the Seebeck effect, it occurs when the following two conditions are present at the same time:

1. An electrical circuit is made from two different conducting materials (metals M1 and M2), which are soldered at their ends, A and B.
2. A temperature difference  $T_2 - T_1$  exists between A and B.

When a junction is formed by two dissimilar metals, and is heated, a voltage is generated due to the different levels of molecular activity within these metals. This electromotive force, induced by temperature, is called Thermal EMF and is usually measured in microvolts. A useful purpose of this Thermal EMF is the measurement of temperature using a thermocouple and microvolt meter.

In resistors, this Thermal EMF is considered a parasitic effect interfering with pure resistance. It is often caused by the dissimilarity of the materials used in the resistor construction especially at the junction of the resistor element and the lead materials. The Thermal EMF performance of a resistor can be degraded by external temperature difference between the two junctions, dissymmetry of power distribution within the element, and the dissimilarity of the molecular activity of the metals involved.

A key feature of the Vishay Bulk Metal<sup>®</sup> Foil resistor is its low Thermal EMF design. The flattened paddle leads make intimate contact with the chip thereby maximizing heat transfer and minimizing temperature variations. The resistor element is designed to uniformly dissipate power without creating hot spots and the lead material is compatible with the element material. These design factors result in a very low Thermal EMF resistor.



**FIGURE 19. RUGGEDIZED CONSTRUCTION**

The combination of ruggedized leads and molded case, plus the highly efficient heat transfer characteristics of the unique assembly and the ceramic substrate results in a high reliability resistor with excellent moisture resistance, high temperature, and load-life capabilities. These also afford a very low Thermal EMF.

Flattened “paddles” are wrapped around the resistance element structure and welded directly to the resistance alloy - thus there is only one weld per lead. The closely related thermal characteristics of the selected materials, combined with the unique “paddle” lead design, produce a resistor with extremely low Thermal EMF.

**Silicone Rubber Encapsulation**

Provides a cushioning layer Which isolates the resistive element from external stresses.

**One Piece Transfer Molded Case**

Affords maximum protection against all environmental conditions.

**Vishay® Metal Foil**

Etched resistive element.

**Polymerized Moisture Protection Layer**

**Molded Standoffs**

Allow easy PC board cleaning.

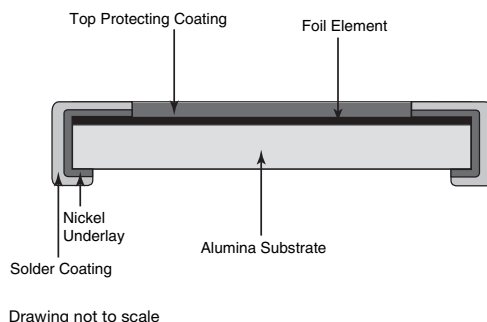
**Ceramic Substrate**

**Paddle Leads with Welded Terminations— No Ribbons**

Only two welds, both remote from the lead-to-case point-of-entry, the best arrangement for maximum reliability. Excellent moisture resistance, high temperature, and load-life capabilities, low Thermal EMF.

**FIGURE 20. SURFACE-MOUNT WRAP-AROUND CHIP FOIL RESISTOR CONSTRUCTION**

Thermal design of surface-mount chip foil resistor produces a resistor with extremely low thermal EMF.



## REASON 7 NON-MEASURABLE VOLTAGE COEFFICIENT

As mentioned earlier in our section on resistor noise, resistors can change value due to applied voltage. The term used to describe the rate of change of resistance with changing voltage is known as voltage coefficient. Resistors of different constructions have noticeably different voltage

coefficients. In the extreme case, the effect in a carbon composition resistor is so noticeable that the resistance value varies greatly as a function of the applied voltage. Vishay Bulk Metal® Foil resistor elements are insensitive to voltage variation and the designer can count on foil resistors having the same resistance under varying circuit voltage level conditions. The inherent bulk property of the metal alloy provides a non-measurable voltage coefficient.

## CONCLUSION ALL IN ONE RESISTOR

The seven reasons to specify Vishay Bulk Metal® Foil resistors are inherent in the design and are not a function of manufacturing variables or a selection process. This combination of parameters is not available in any other resistor technology.

Vishay Bulk Metal® Foil resistors provide a unique, inherent combination of performance characteristics resulting in unmatched performance and high reliability satisfying the needs of today's expanding requirements.

## SPECIAL ORDER

Consider Vishay Bulk Metal® Foil Resistors for all of your low TCR needs. Special orders may be placed for low TCR, low value resistors, and tight TCR tracking of individual resistors and network combinations. Contact the Applications Engineering Department to discuss your requirements for these and any other TCR applications. (email: foilsupport1@vishay.com).